

Assembly and User Manual **CUSTERS® De-icing Scaffold**

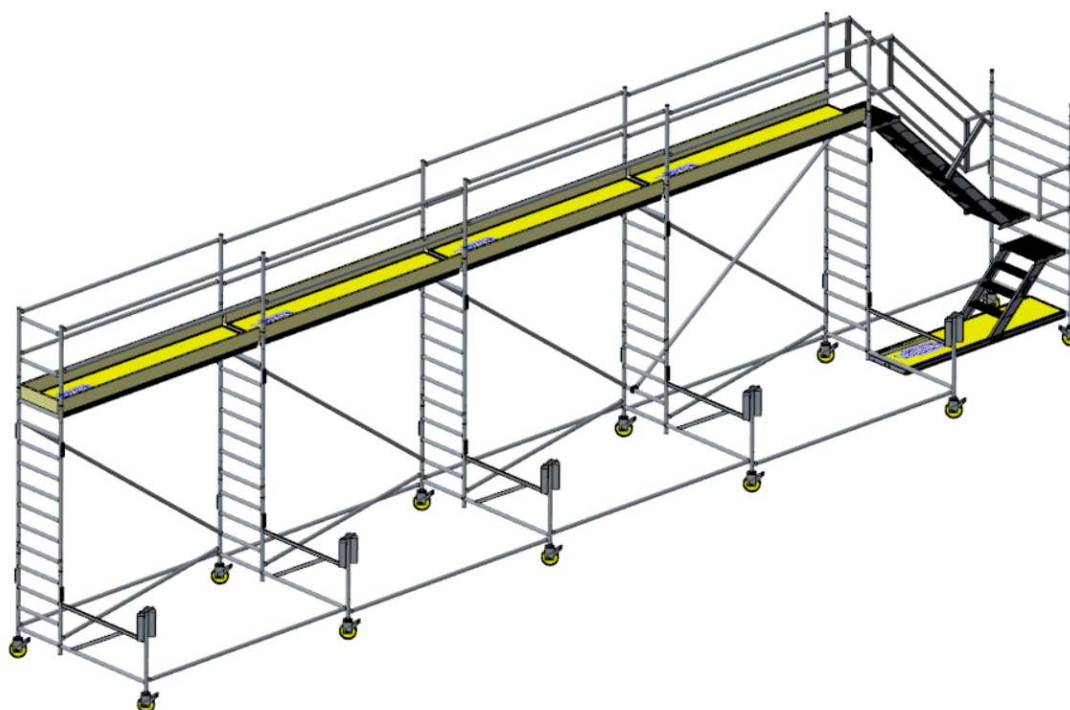

Maximum load: 200 kg/m²

Maximum platform height: 3.15-3.30 meters

9505200820EN

May 2026

Safe access

Table of Contents

1. Introduction	3
2. Specifications	4
3. Warranty and liability	4
4. Coding of scaffolding components	4
5. Controle van de levering	5
6. Safety instructions	5
6.1. Pre-assembly Check	5
6.2. Personal Protective Equipment and Tools	5
6.3. Assembly	6
6.4. Raising parts	6
7. Assembly instructions	7
7.1. Assembly of the work platform	7
7.2. Construction of a fixed staircase	14
7.3. Access via ladder	17
8. Use of the scaffolding	18
9. Moving the scaffolding	19
10. Scaffolding maintenance	19
11. Guidelines for use, transport and storage	20
12. Composition table	21
12.1. Ice scaffolding work platform	21
12.2. Bracket for ballast	22

1. Introduction

The Custers ice scaffold is part of a wide range of aluminum scaffold models. When assembled in accordance with this manual, the Custers ice scaffold complies with the following standards: EN 1004 and EN 1298.

This manual is intended to provide step-by-step instructions for assembling your scaffold easily and safely. Incorrect assembly may pose a danger to the user. Please read the safety instructions carefully before assembly. Assembly and disassembly must be performed by experienced and qualified personnel.

The user is responsible for ensuring that the manual is available at the location where the scaffold is being assembled and used, as well as to the person supervising the work.

If you have any questions regarding this manual, please contact your supplier and/or manufacturer.

Producent:

Custers Hydraulica B.V.
Smakterweg 33
5804 AE Venray Nederland
Phone: +31 (0) 478 553 000
E-mail: info@custers.nl
Website: www.custers.nl

Supplier:



2. Specifications

Standard:	NEN-EN 1004
Scaffolding class:	3
Max. load:	200 kg/m ²
Max. platform height:	3,3m
Max. wind load:	6 Beaufort

3. Warranty and liability

Custers provides a warranty for material and manufacturing defects up to 12 months after delivery. The warranty means that we repair the errors at our expense or - at our sole discretion - take back all or part of the delivered goods and replace them with a new delivery.

If we replace products delivered in fulfilment of our warranty obligation, the replaced products become our property. All costs that exceed the obligation described above are for the account of the Client. If products are provided for processing, repair, etc., only a guarantee is given for the soundness of the execution of the commissioned operations.

Our liability does not apply:

- a. If the defects are the result of improper use or of causes other than defectiveness of material or workmanship;
 - b. If the cause of the errors cannot be clearly demonstrated;
 - c. If not all instructions given for the use of the products, including the guidelines as indicated in this manual, have been strictly and completely complied with.
- The manufacturer's liability does not apply if the buyer, on its own initiative, makes or has made modifications and/or repairs to the delivered products.

4. Coding of scaffolding components

- Each aluminum or plastic cast component of the folding scaffold is marked with the Custers company name and a two-digit code indicating the year of manufacture.
- 8-Sports windows always come with a mandatory waterproof label indicating the scaffold class and installation instructions.

5. Controle van de levering

Upon receipt, check that the ice scaffold has been delivered complete and undamaged.

Contact your supplier immediately if you notice that any parts of the ice scaffold are damaged or that the delivery is incomplete.

6. Safety instructions

6.1. Pre-assembly Check

Verify that the technicians are sufficiently qualified and check that the location where the scaffold is to be erected is safe and suitable

Note:

- The ground must be sufficiently load-bearing and level;
- The area must be free of obstacles both on the ground and above ground;;
- Ensure that wind conditions are suitable for working with the scaffold;
- Verify that all components and any ropes required for hoisting are present at the work site.
- Damaged, wrong or non-original parts may never be used.

6.2. Personal Protective Equipment and Tools

- Always wear work gloves, safety shoes, and a hard hat.
- Sturdy rope for manually hoisting parts or tools.
- Attaching fall protection to the scaffold is not permitted. (If fall protection is necessary, use the existing facade or another solid building structure.)

6.3. Assembly

The assembly of the scaffold is described in the assembly instructions and must be performed by at least two people.

The scaffold must be set up on a level surface. A maximum deviation of 1% (= 1 cm per 100 cm) is permitted. The wheels must always be on the brake, except when moving the scaffold. Ensure that the wheels are locked by pushing the lock down.

The platforms must be secured by sliding the safety catch pin under the rung. The windows must be secured to each other using the locking pin. The handrails (horizontal rungs) must be attached to the uprights so that the openings of the clamps face outward.

The work platform must be equipped with hip rails, knee rails, and toe boards.

6.4. Raising parts

The raising of parts for higher sections must be carried out by passing the parts upwards. Hoisting equipment must not be attached to the scaffolding.

7. Assembly instructions

7.1. Assembly of the work platform



- 1: Insert two wheels (table no. 3) into a base frame (table no. 1). Make sure the wheels are securely fastened.
- 2: Place two horizontal bars (table no. 4) and the horizontal-diagonal bar (table no. 5) in the positions shown in the illustration above.

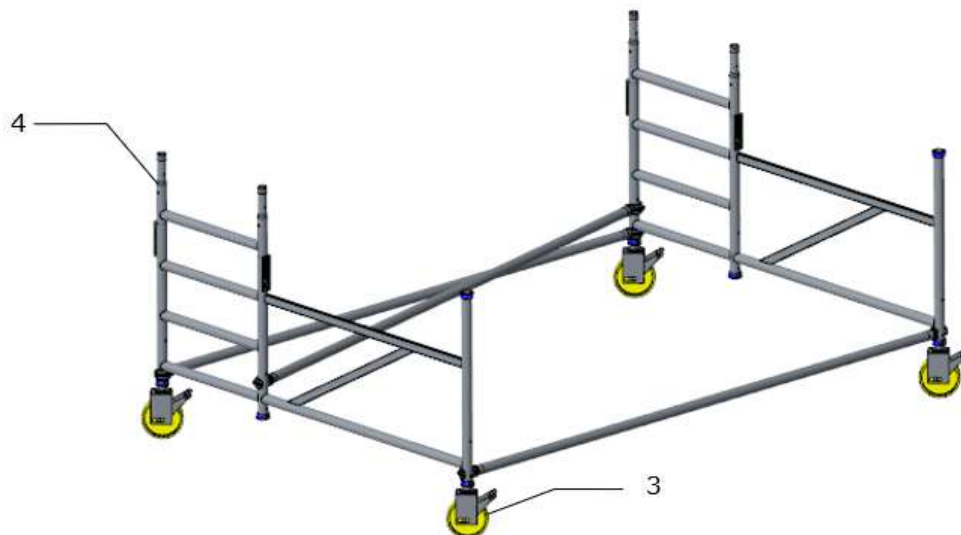

- 3: Insert two more wheels into the next base frame. Make sure the wheels are securely fastened.
- 4: Attach this second frame to the horizontal and horizontal-diagonal pieces so that they are connected to each other.

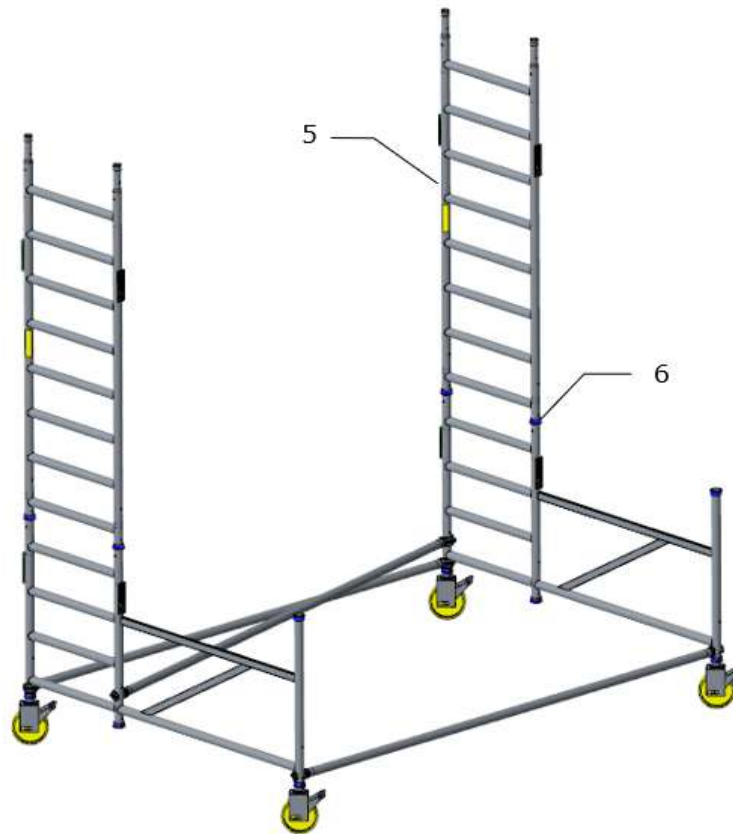

5: Place two 8-step frames (table no. 2) on the two base frames.

6: Insert the retaining springs (table no. 16) on both sides to secure the frames.

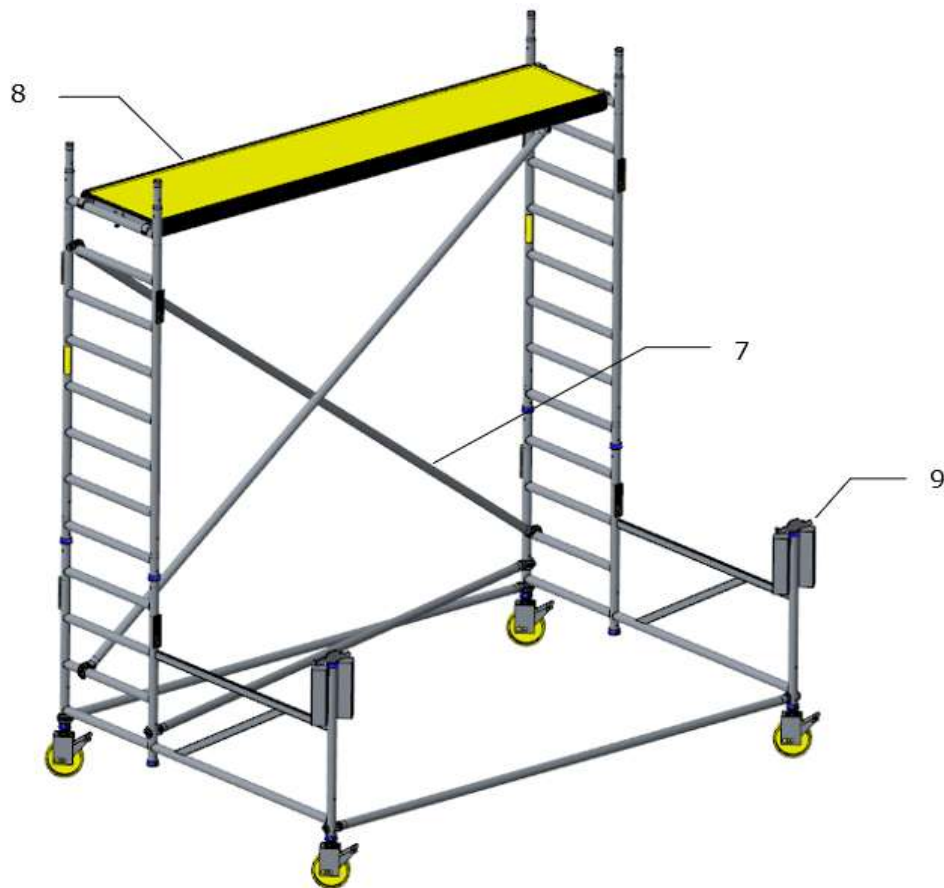

- 7: Install both diagonal braces (table no. 6).
- 8: Place the work platform (table no. 7) and slide both anti-tip guards under the rung.
- 9: Insert the ballast holders (table no. 14) into the uprights of the base frames. Place a ballast weight (table no. 15) in the designated recess on both sides.

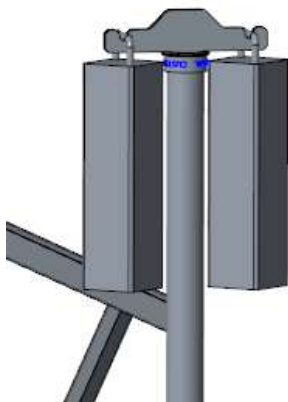

Detail ballast holder with ballast weights

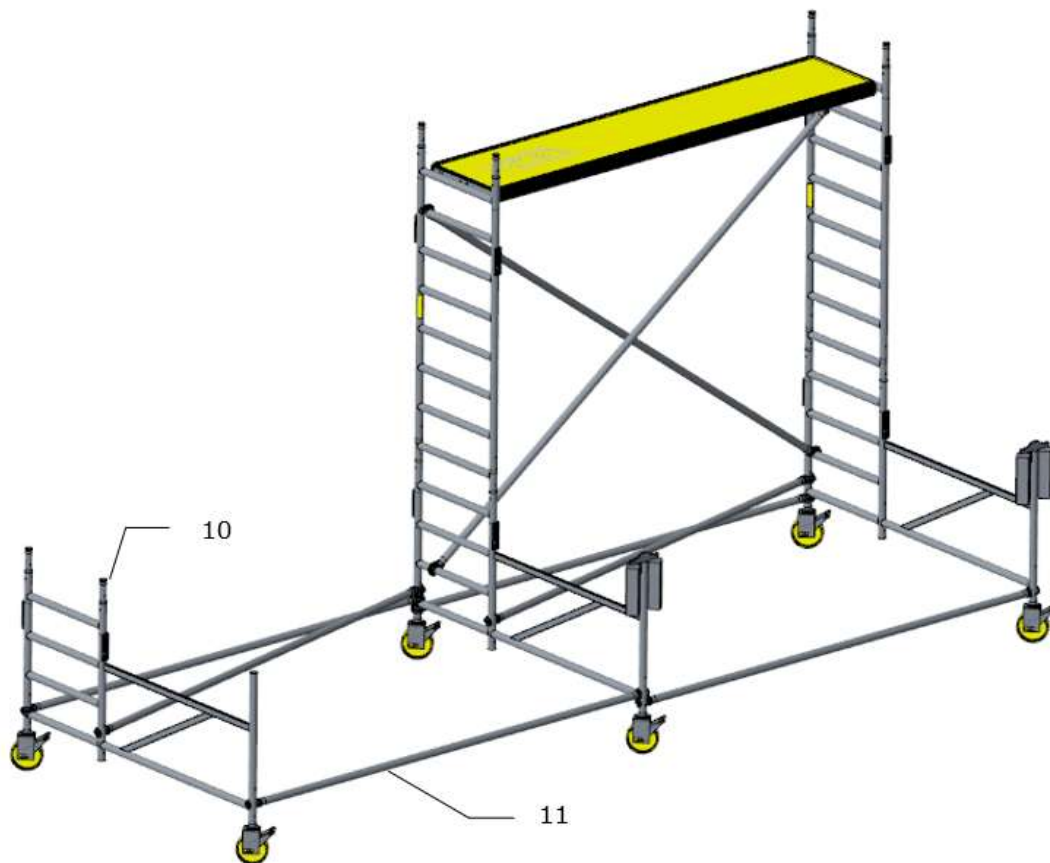

- 10: Insert two wheels (Table 3) into a base frame (Table 1) again. Make sure the wheels are securely fastened.
- 11: Place two horizontal bars (table no. 4) and the horizontal-diagonal bar (table no. 5) in the positions shown in the image above to connect the new frame to the rest.

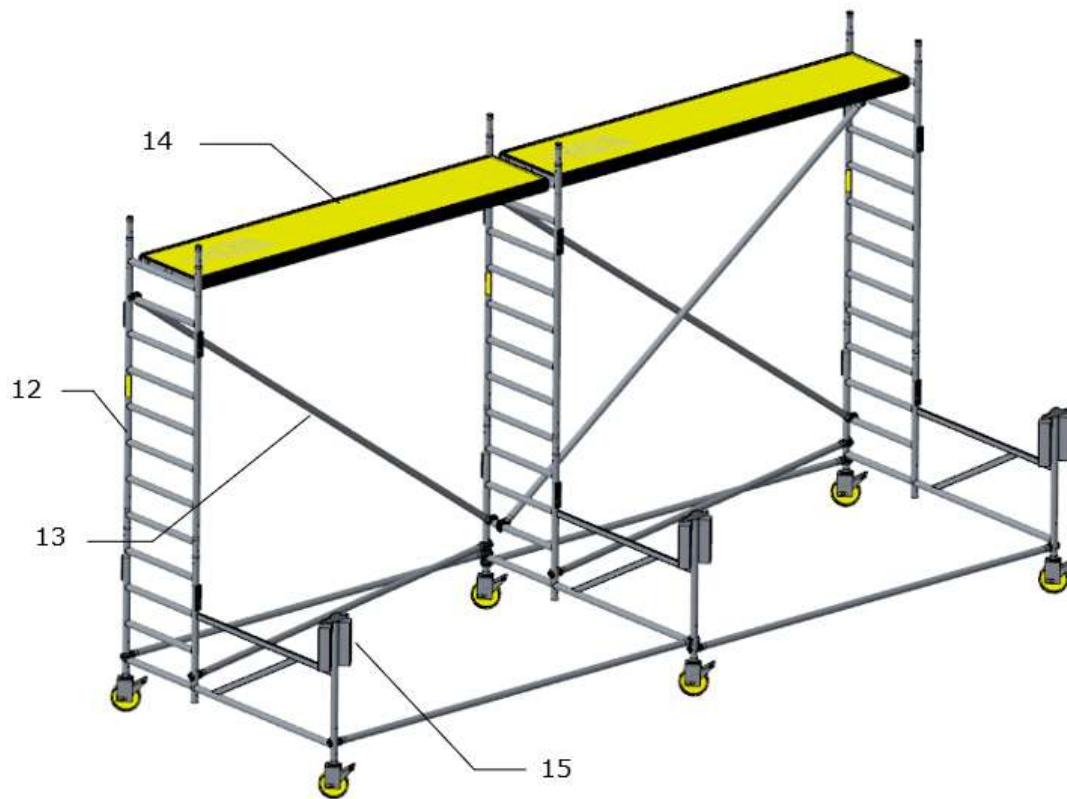

- 12: Place an 8-step ladder (table no. 2) on the base frame and secure it with two retaining springs (table no. 16).
- 13: Install a single diagonal brace (table no. 6) as shown in the illustration above. Only the first section should be fitted with two braces.
- 14: Place the work platform (part no. 7) and slide both anti-tip guards under the rung.
- 15: Insert the ballast holder (part no. 14) into the upright of the base frame. Place a ballast weight (part no. 15) in the designated recess on both sides.

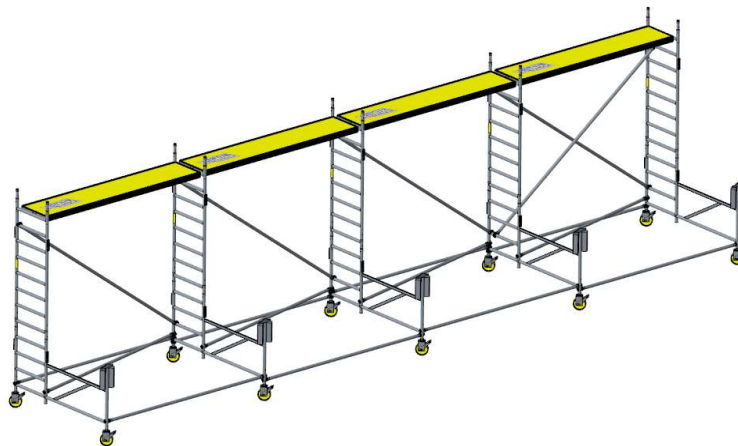

(Depending on the size of the scaffold, steps 10 through 15 may need to be repeated a few more times.)

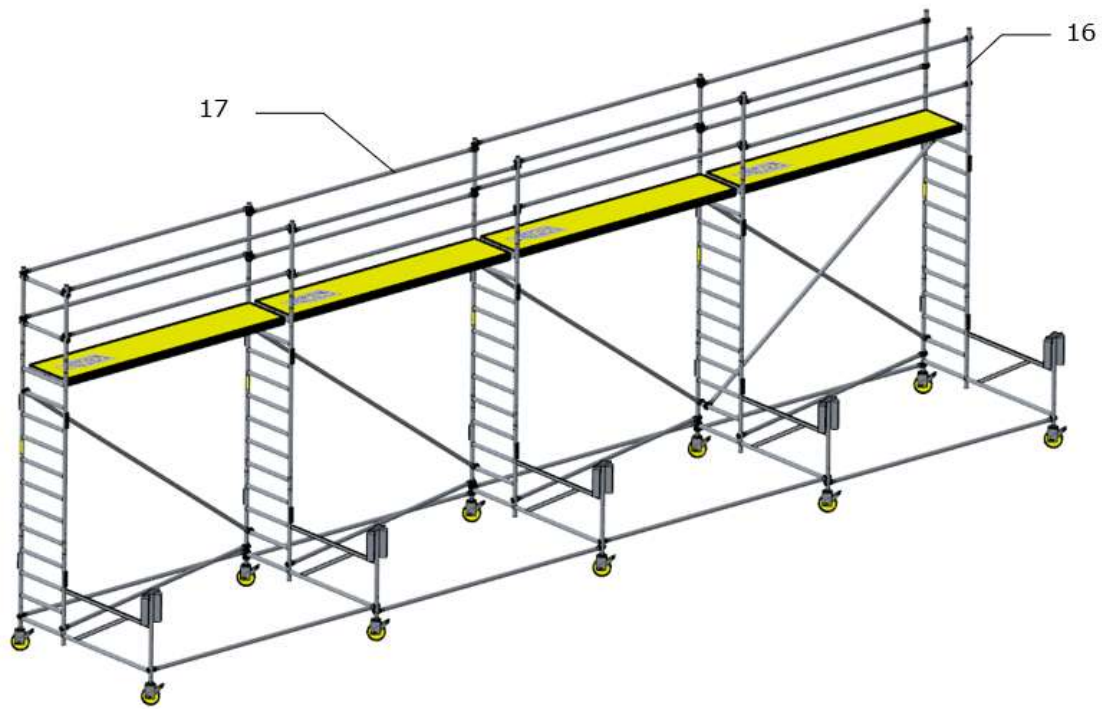

- 16: Install the handrail posts (table nos. 8 and 9). Make sure the two handrail posts with a hole at the top (table no. 9) are located on the access side. Secure the handrail posts with a retaining spring (table no. 16).
- 17: Install the handrails (table nos. 4 and 10) at both knee and hip height on all sides except the access side.

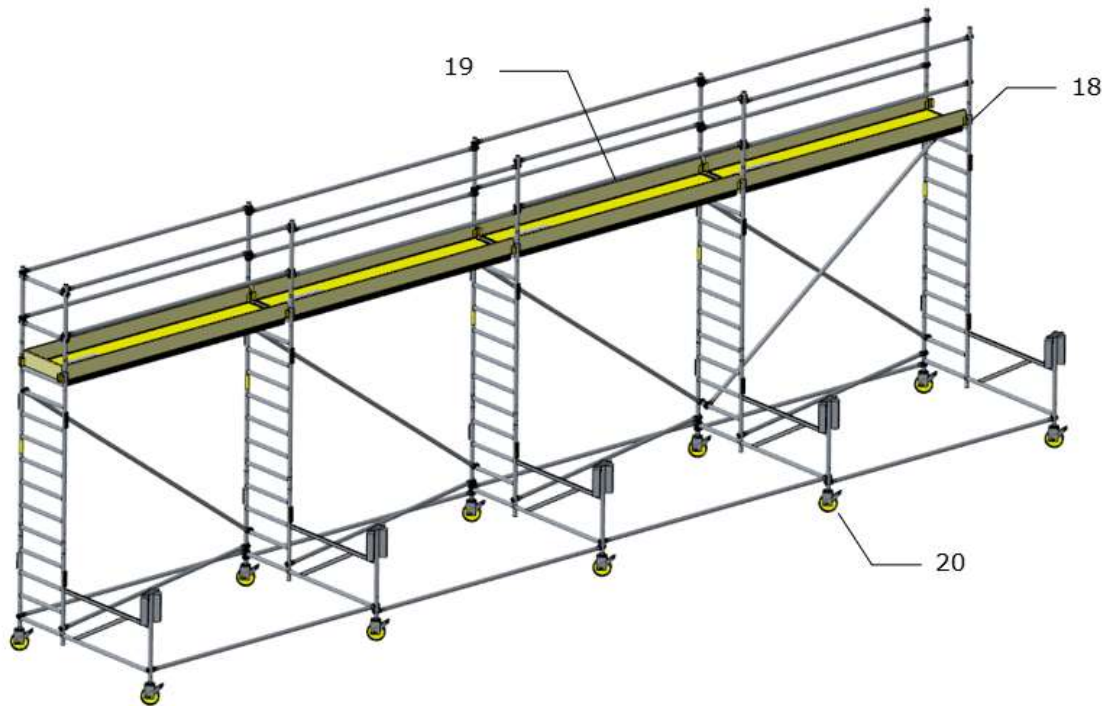

- 18: Install an edge board holder on each upright (table no. 11).
- 19: Install an edge board on all sides (table nos. 12 and 13), except for the access side.
- 20: Lock the brakes and level the scaffold by turning the spindle nuts on the wheel spindles.

7.2. Construction of a fixed staircase

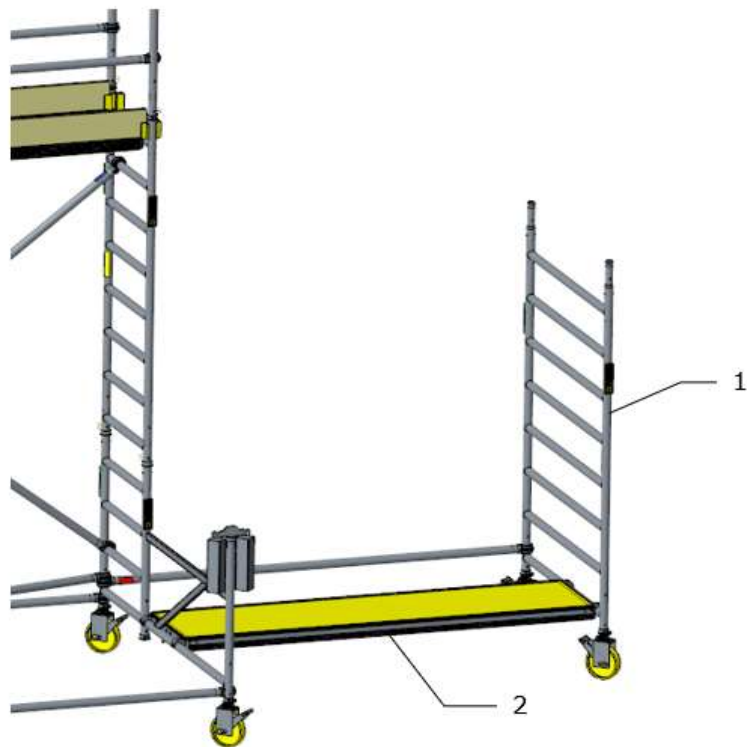

- 1: Insert two wheels (Table No. 4) into the uprights of a wide 8-pane window (Table No. 1). Make sure the wheels are securely fastened.
- 2: Place a horizontal 2500 (table no. 3) and the 2500 platform (table no. 5) in the positions shown in the illustration above.

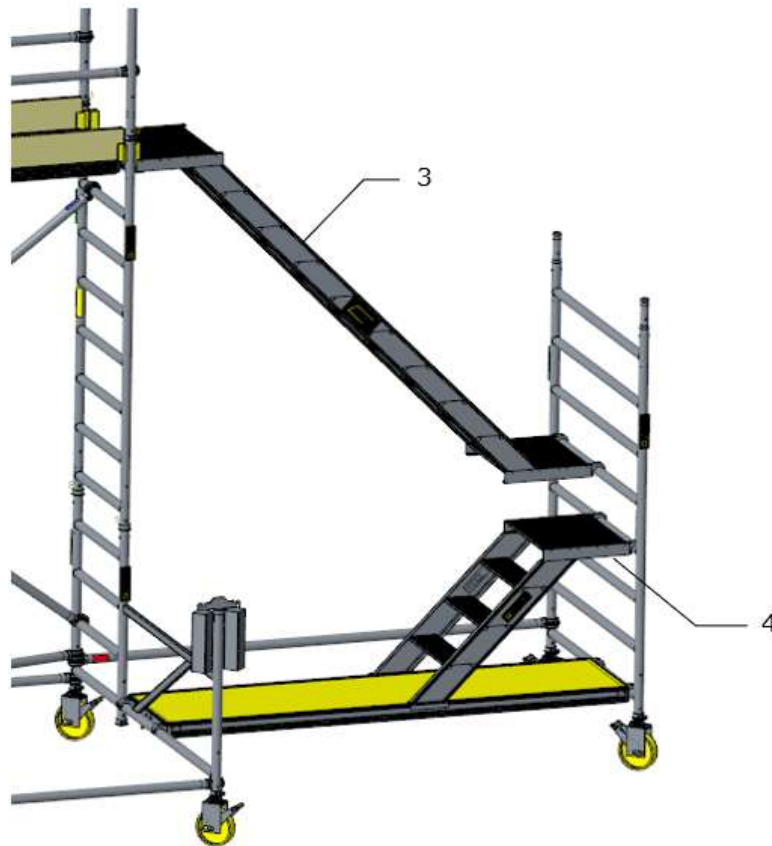

- 3: First, install the large Z-shaped staircase (table no. 7) so that the frames are connected to each other.
- 4: Only then should you install the small staircase (table no. 6) above the platform. Make sure the edges of the stair treads on both sides align with the platform so that the staircase cannot shift.

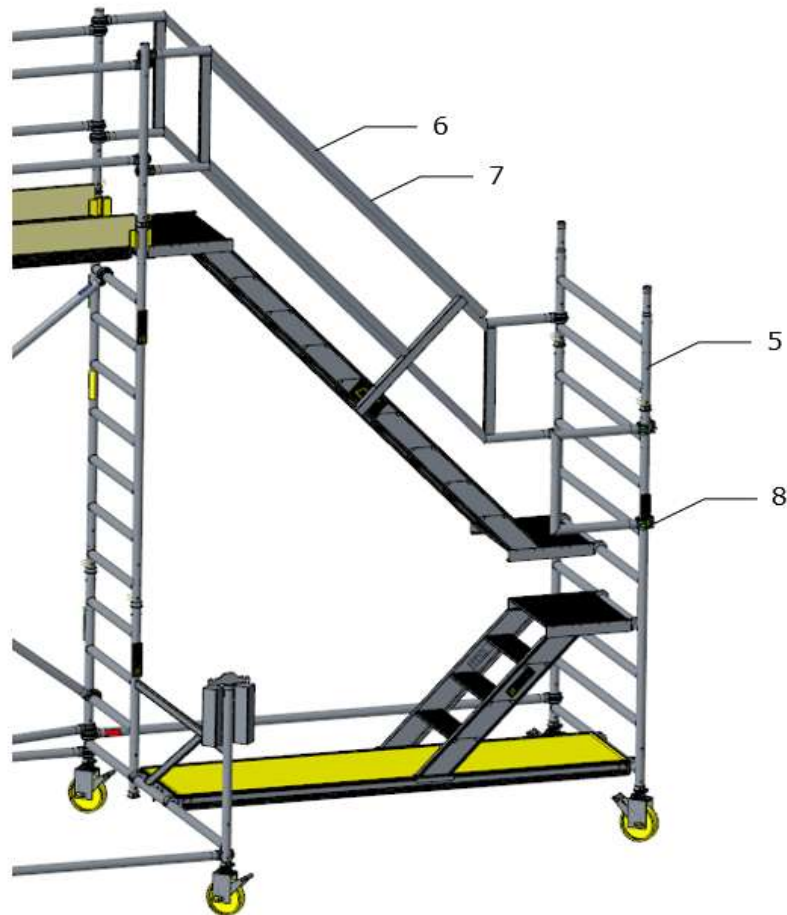

- 5: Place the wide 2-step frame (item no. 2) on top of the 8-step frame and secure it with 2 retaining springs (item no. 11).
- 6: Place the Z-handrail (table no. 8) on the outside of the large staircase. Make sure the openings of the brackets face outward. Note: the horizontal end of the handrail is shorter on one side than on the other. The shorter section must be at the top.
- 7: Place the inner handrail (table no. 9) on the inside of the large staircase. Secure the handrail at the bottom by hooking it onto the stair stringer and then tightening the wing nut.
- 8: Place the U-shaped handrail (table no. 10) on the right side above the small staircase and secure it to the upright of the 8-step frame.

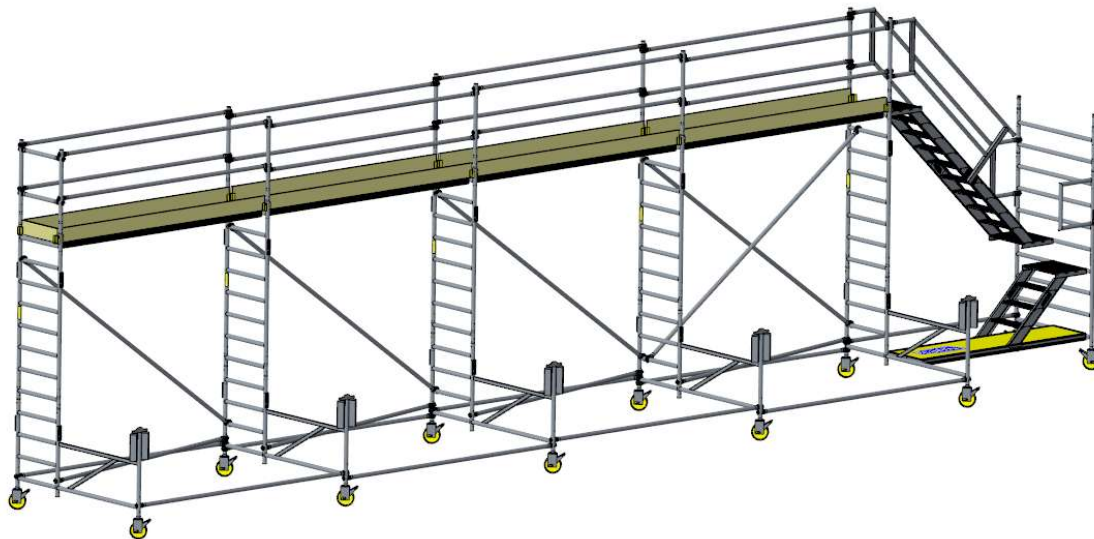

10: The aluminum ice scaffolding is now ready for use.

7.3. Access via ladder

Instead of a fixed staircase, it is also possible to use a ladder (9501.300.046) together with a chain (9509.903.143) to access the work platform.

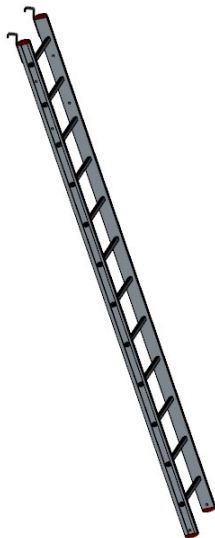

8. Use of the scaffolding

Before each use, check that:

- The foundation (wheel braking mechanism) of the ice scaffold is in proper working order
- The entire structure is correct and complete;
- There are changes in circumstances that could affect the safe use of the scaffolding.

An ice scaffold is intended to provide access to a work area; it is not permitted to use the scaffold as a stair tower for other structures.

Nor is it permitted to use the scaffold as suspended scaffolding, for cantilevered work platforms, or to use the scaffold to cross over to other structures.

No bridges may be constructed between an ice scaffold and a building.

No bridges may be constructed between scaffolds, unless specifically designed for this purpose.

The maximum working load is 200 kg/m² (scaffold class 3).

Jumping on the platforms is prohibited; the platform hatch must always be closed, except when ascending or descending.

The scaffolding may only be accessed from the inside, through the windows, or via a designated ladder or access staircase.

Do not place boxes, ladders, or other aids on the work platform to gain height. It is prohibited to work on the scaffold if the wind force exceeds 6 Beaufort (large branches are moving, umbrellas are turning inside out, wind speed is 11–14 m/s = ± 45 km/h). If wind speeds are expected to exceed 6 Beaufort, the freestanding scaffold must either be dismantled, moved to a wind-protected area, or anchored. This must also be done when the scaffold is not in use. Caution: Be aware of openings in buildings, unclad buildings, and building corners, which can create additional wind loads.

Note: When applying horizontal forces (e.g., drilling), which push the scaffold away from a structure; the maximum horizontal load is 300 N.

Horizontal members, handrails, knee rails, and diagonal braces must not be used as steps. It is prohibited to attach wind-catching surfaces, such as billboards or tarps, to freestanding scaffolding. The scaffolding must not be exposed to corrosive liquids or gases.

9. Moving the scaffolding

The scaffold may only be moved by hand from the ground in a longitudinal direction. While moving the scaffold, do not exceed normal walking speed, and ensure that no people or materials are on the scaffold. When moving the scaffold, watch out for obstacles both on and above the ground.

When wind speeds exceed 4 Beaufort, the scaffold must not be moved (dust, sand, and paper are blown about, small branches are snapped off: wind speed is 4–6 m/s = ±18 km/h). Exercise caution when moving the scaffold on unsuitable surfaces (sloped surfaces, insufficient load-bearing capacity, holes, etc.): ensure that the wheels are braked or released at the appropriate times.

10. Scaffolding maintenance

All components, especially moving parts and welds, must be inspected regularly—at least once a year—for wear and damage.

Missing or broken parts must be replaced.

Aluminum components must not be used in the following cases:

- If round tubes have one or more dull dents with a depth of more than 3.0 mm.
- If round tubes have one or more dents immediately adjacent to a welded joint, regardless of the depth and shape of the dent.
- If square/rectangular tubes have one or more dull dents with a depth of more than 2.0 mm.
- If pipes or tubes have one or more sharp dents or cracks, regardless of the length, depth, and location of the dent(s) or crack.

Moving parts, including wheels, must be clean and running smoothly.

Repair of scaffolding material should always be done in consultation with the manufacturer.

11. Guidelines for use, transport and storage

Scaffolding components must be handled and transported with care to prevent damage.

- Storage must be arranged in such a way that only undamaged parts are available in the correct numbers for the erection of the scaffolding.
- All parts must be checked before assembly, proper functioning and free of contamination or damage.
- Damaged parts must not be used and must be replaced or presented to the supplier for inspection/assessment.
- No tools may be used when assembling and disassembling the mobile scaffold.
- Scaffolding for professional use must be inspected annually by a competent authority/inspector.
- After exposure to extreme forces such as storms, etc., the scaffolding must be inspected again before it is put into use.
- Hoisting or hanging the scaffolding is not permitted.

12. Composition table

The following table shows which parts are needed to erect a folding scaffold to a certain height. Make sure these parts are also present.

12.1. Ice scaffolding work platform

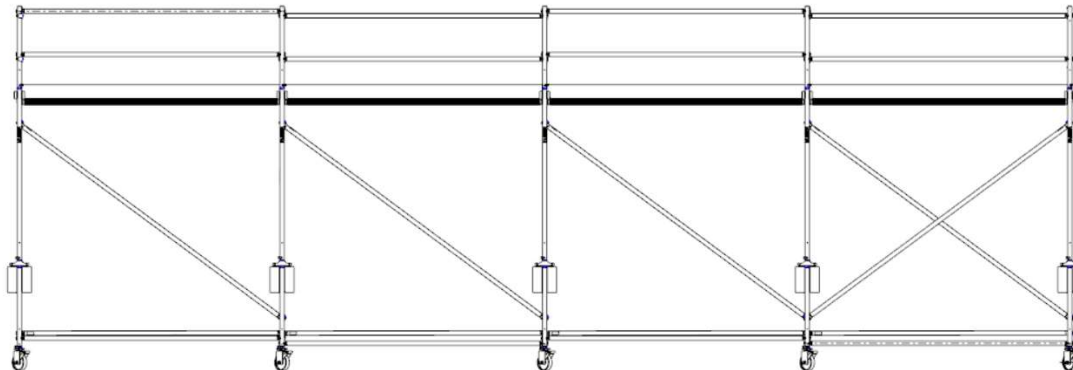

Composition table ice scaffold work platform (9501200810)

Nr.	Description	Article number	Kg	Platform size (m*m)			
				3,0x0,7	6,0x0,7	9,0x0,7	12,0x0,7
1	Ice scaffold base frame	9501.200.820	8,3	2	3	4	5
2	8-Step Frame 690	9501.200.012	8,9	2	3	4	5
3	Swivel wheel plastic	9501.510.050	5,9	4	6	8	10
4	Horizontal 3052	9501.200.040	3,3	6	12	18	24
5	Horizontal/diagonal	9501.200.054	3,4	1	2	3	4
6	Diagonal 3792	9501.902.042	3,9	2	3	4	5
7	Platform 3052	9501.311.030	17,1	1	2	3	4
8	Handrail post	9501.903.050	0,9	2	4	6	8
9	Handrail post	9501.200.816	0,9	2	2	2	2
10	End handrail 690	9501.903.040	2,9	1	1	1	1
11	Kickboard holder	9501.800.087	0,3	4	6	8	10
12	Kickboard 690	9501.200.092	1,9	1	1	1	1
13	Kickboard 3052	9501.902.080	9,4	2	4	6	8
14	Bracket for ballast	9501.200.753	0,3	2	3	4	5
15	Ballast block 15 Kg	9501.800.960	15,1	4	6	8	10
16	Locking pin	9501.410.162	-	8	12	16	20

12.2. Bracket for ballast

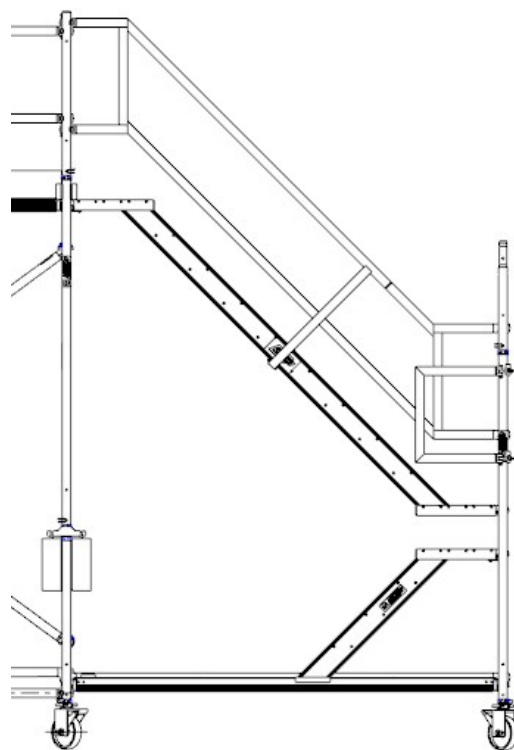

Composition table ice scaffold staircase (9501200782)

Nr.	Description	Article number	Kg	Amount
1	8-Step Frame 1300	9501.200.010	13,2	1
2	2-Step Frame 1300	9501.200.025	3,8	1
3	Horizontal 2500	9501.200.030	2,8	1
4	Plastic castor wheel	9501.510.050	5,9	2
5	Platform 2500	9501.311.020	13,7	1
6	Stairs 750	9501.600.410	8,8	1
7	Stairs 2500 x 1750	9501.600.370	19,6	1
8	Z-handrail 2500 x 750	9501.600.430	7,8	1
9	Inner railing	9501.600.470	6,3	1
10	U-handrail	9501.920.072	2,6	1
11	Locking pin	9501.410.162	-	2



Custers Hydraulica B.V.
Smakterweg 33
5804 AE Venray
The Netherlands
Tel. +31 (0) 47 85 53 000
E-mail: info@custers.nl
Website: www.custers.nl